

MERITOR® MTA TRAILER SUSPENSION SYSTEMS



MTA25

MTA30

MTA23

DURABILITY FOR VOCATIONAL MARKETS



MERITOR®

DURABILITY RUNS IN THE FAMILY

The Meritor trailing arm air ride suspension delivers **INDUSTRY-LEADING RIDE, HANDLING, TIRE LIFE AND DURABILITY**. This hardworking trailer suspension is designed for a full range of demanding vocational applications from flatbeds to tanks to dumps. Available in 23,000 lb. to 30,000 lb. capacities, the MTA Family includes the MTA23, MTA25 and MTA30.

BEYOND THE BENCHMARK

The MTA is the product of extensive design and development work. Exhaustive modeling, analysis and prototyping led to an innovative structure and manufacturing process which has been validated in the laboratory, on independent proving grounds and in real-world applications. The result is a suspension system that substantially exceeds industry durability benchmarks.

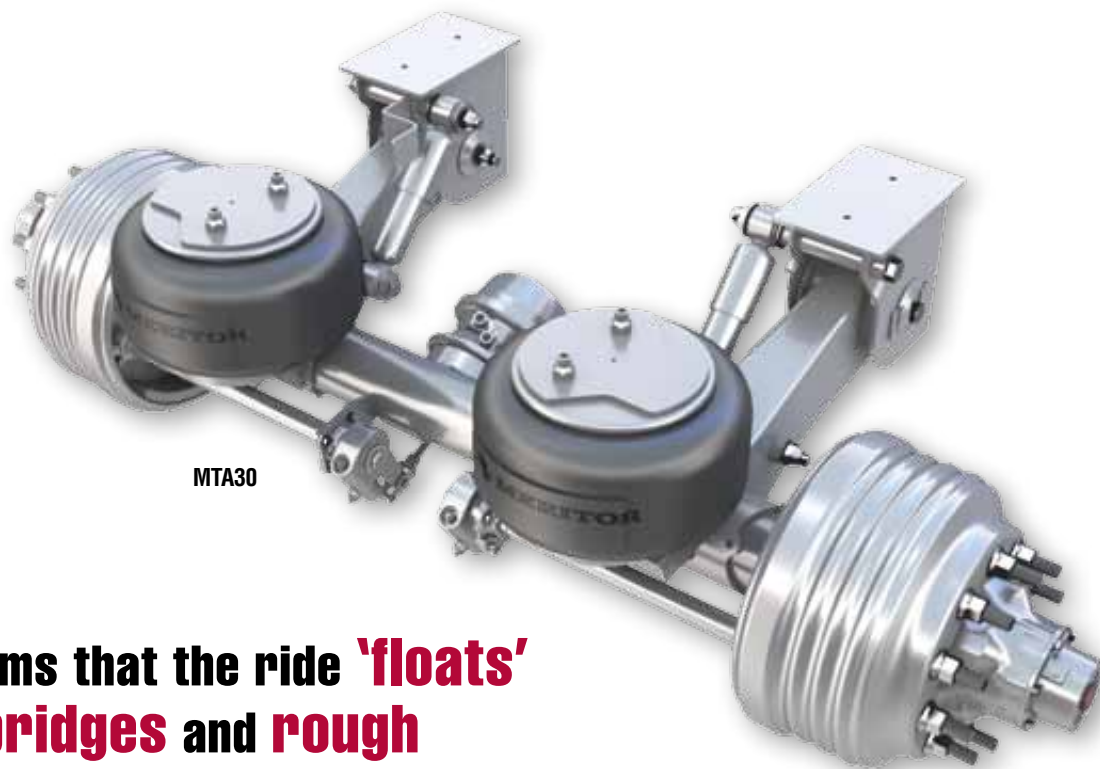

"It seems that the ride 'floats' over bridges and rough places in the road."

Gary New, Owner/ President GNT, Inc.



FORWARD THINKING TECHNOLOGY

INNOVATIONS THAT EXCEED EXPECTATIONS

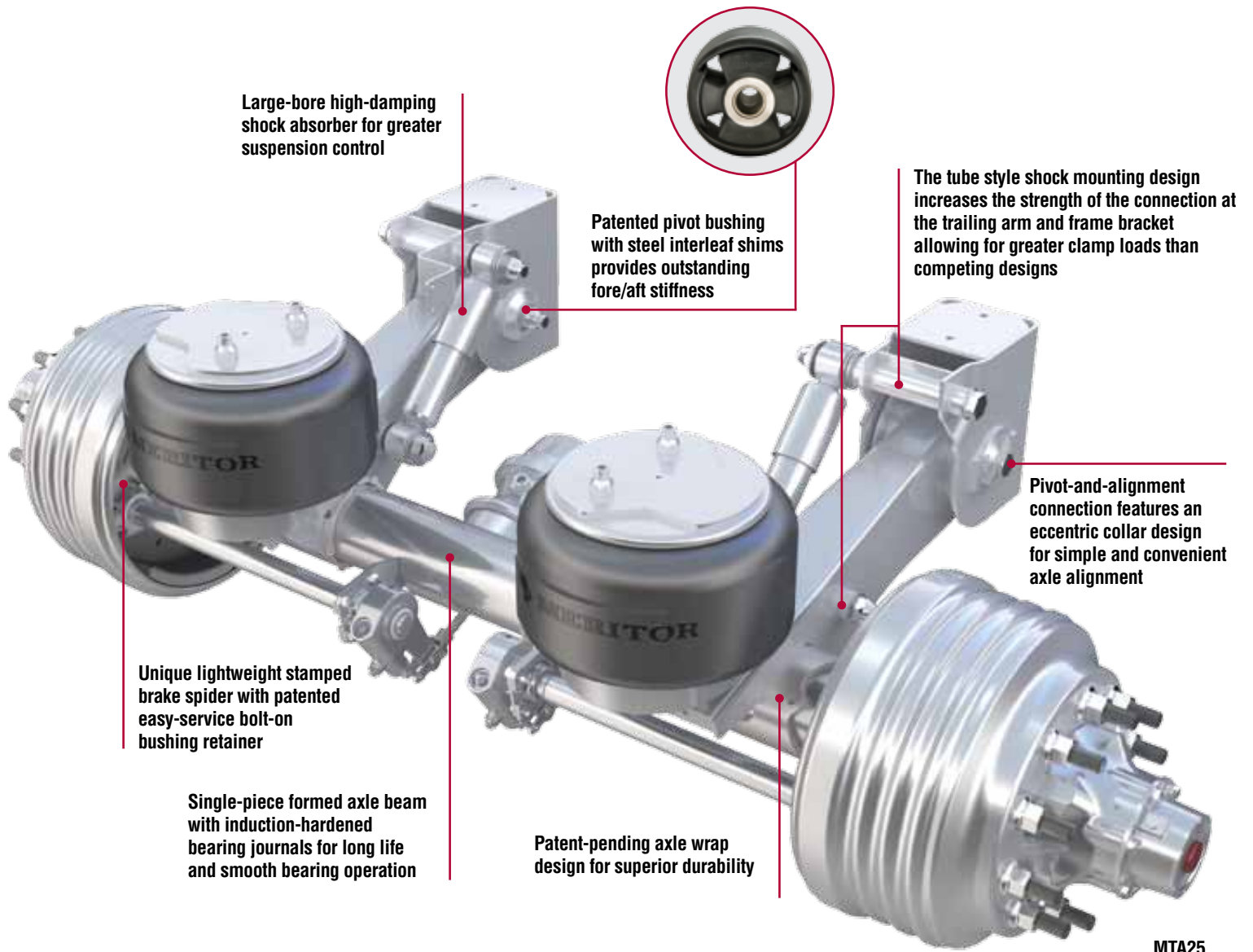

"The Meritor MTA series suspension family utilizes **forward-thinking technology** to set new standards in **ride, handling, tire life, and durability...**"

Tank Talk – A Burch Publication

THE NEW STANDARD IN AIR RIDE SUSPENSIONS

FEATURES AND BENEFITS

DURABLE

- An innovative axle wrap design provides a secure axle connection for greater overall suspension durability
- The larger, more robust shock absorber, specifically tuned to the suspension, provides superior damping force, braking performance and vehicle control

SUPERIOR RIDE QUALITY

- Patented pivot bushing absorbs road inputs for improved ride and cargo protection
 - Interleaf shims provide better fore/aft stiffness than competing designs
 - Maintains better axle alignment down the road
 - Reduces tire wear and roll induced steer

LIGHTWEIGHT

- The MTA is one of the lightest suspensions in its market segment, allowing for larger payloads

INTEGRATED DESIGN

- “Plug and Play” design for simple installation – designed to fit common installation envelopes on a variety of trailer frames
- Integrated design includes genuine Meritor axles and brakes – recognized as the industry’s best

AMAZING SUPPORT

- Comprehensive Meritor parts availability with more than 5,000 dealer and distributor outlets across North America
- Industry-leading customer support through Meritor’s OnTrac customer service center. The OnTrac team is staffed with Meritor product experts dedicated to assisting dealer, fleet and end user customers with diagnostics, technical support and warranty guidance
- Proven Meritor components including: industry leading Q Plus™ brakes, high performing air disc brakes, long life brake linings, compact automatic slack adjusters, and a variety of hubs and wheel end technologies



OPTIONAL LIFT KIT

The MTA Lift Kit is a durable, reliable quick-response system that allows users to efficiently raise select axles, improving maneuverability and extending tire life. Available in painted or galvanized finishes, the lift kit attaches easily and can be installed by the OEM or as a field retrofit on the MTA23, MTA25 and MTA30.

MTA with optional Lift Kit

SPECIFICATIONS

MTA TRAILER SUSPENSION SYSTEM

| PRODUCT | CAPACITY (GAWR) | APPLICATIONS | SYSTEM BASE WEIGHT** (Pounds) |
|---------|-----------------|---|-------------------------------|
| MTA23 | 23,000 lbs.* | Platform/flatbed, liquid and dry bulk tank, grain, bottom-discharge dump, container chassis, livestock, fixed axle van and reefer | 530 |
| MTA25 | 25,000 lbs.* | Platform/flatbed, liquid and dry bulk tank, bottom-discharge dump, transfer, end dump, side dump | 582 |
| MTA30 | 30,000 lbs.* | Liquid and dry bulk tank, transfer, end dump, side dump, logging, chip hauler | 627 |

*Suspension and axle beam rating only; brake and wheel-end components rated separately.

** Base model illustrated below by hardware denoted as "Standard"

RIDE HEIGHT RANGE AND AXLE TRAVEL

| RIDE HEIGHT (Inches) | MTA23 | | MTA25 | | MTA30 | |
|----------------------|-----------------|------------------|-----------------|------------------|-----------------|------------------|
| | JOUNCE (Inches) | REBOUND (Inches) | JOUNCE (Inches) | REBOUND (Inches) | JOUNCE (Inches) | REBOUND (Inches) |
| 14 | 2.8 | 4.0 | 3.0 | 4.0 | 2.9 | 4.3 |
| 15 | 3.0 | 4.0 | 3.2 | 4.0 | 3.1 | 4.3 |
| 16 | 3.0 | 4.0 | 3.2 | 4.0 | 3.1 | 4.3 |
| 17 | 3.0 | 4.0 | 3.2 | 4.0 | 3.1 | 4.3 |

AVAILABLE OPTIONS

| OPTION | MTA23 | MTA25 | MTA30 |
|--------------|--------------------------|-------|-------|
| Axle Track | 71.5" | S | S |
| | 77.5" | O | O |
| | 83.5" | O | O |
| Spindle | TN | S | |
| | TQ | | S |
| | TP | O | O |
| Brake Lining | MA212 | S | S |
| | MA312 | | O |
| Brakes | 16.5" x 7" Q.Plus (Drum) | S | S |
| | EX225 (Disc) | O | O |
| Ride Height | 14" | S | S |
| | 15" | O | O |
| | 16" | O | O |
| | 17" | O | O |

| OPTION | MTA23 | MTA25 | MTA30 |
|--|------------|-------|-------|
| Lift Kit | O | O | O |
| Finish | Painted | S | S |
| | Galvanized | O | O |
| Frame Attachment | Weld-on | S | S |
| | Bolt-on | O | O |
| MTIS by P.S.I. - Meritor Tire Inflation System | O | O | O |
| Meritor Automatic Slack Adjusters, SteelLite™ X30 Drums, Hubs/Wheel Ends, Height Control Valve, Service Brakes | O | O | O |

S = STANDARD O = OPTIONAL





MERITOR®

Meritor Heavy Vehicle Systems, LLC

2135 West Maple Road
Troy, Michigan 48084 USA

**For more information,
call OnTrac at 866-668-7221
meritortrailersuspensions.com
meritor.com**

Litho in USA Issued 9-11
SP-11133 (47865/11900)
©2011 Meritor, Inc.

Vehicle models, brands and names depicted herein are the property of their respective owners, and are not in any way associated with Meritor, Inc., or its affiliates.