

MERITOR®

RIDSENTRY™ MPA SERIES WITH PINLOC™ SYSTEM

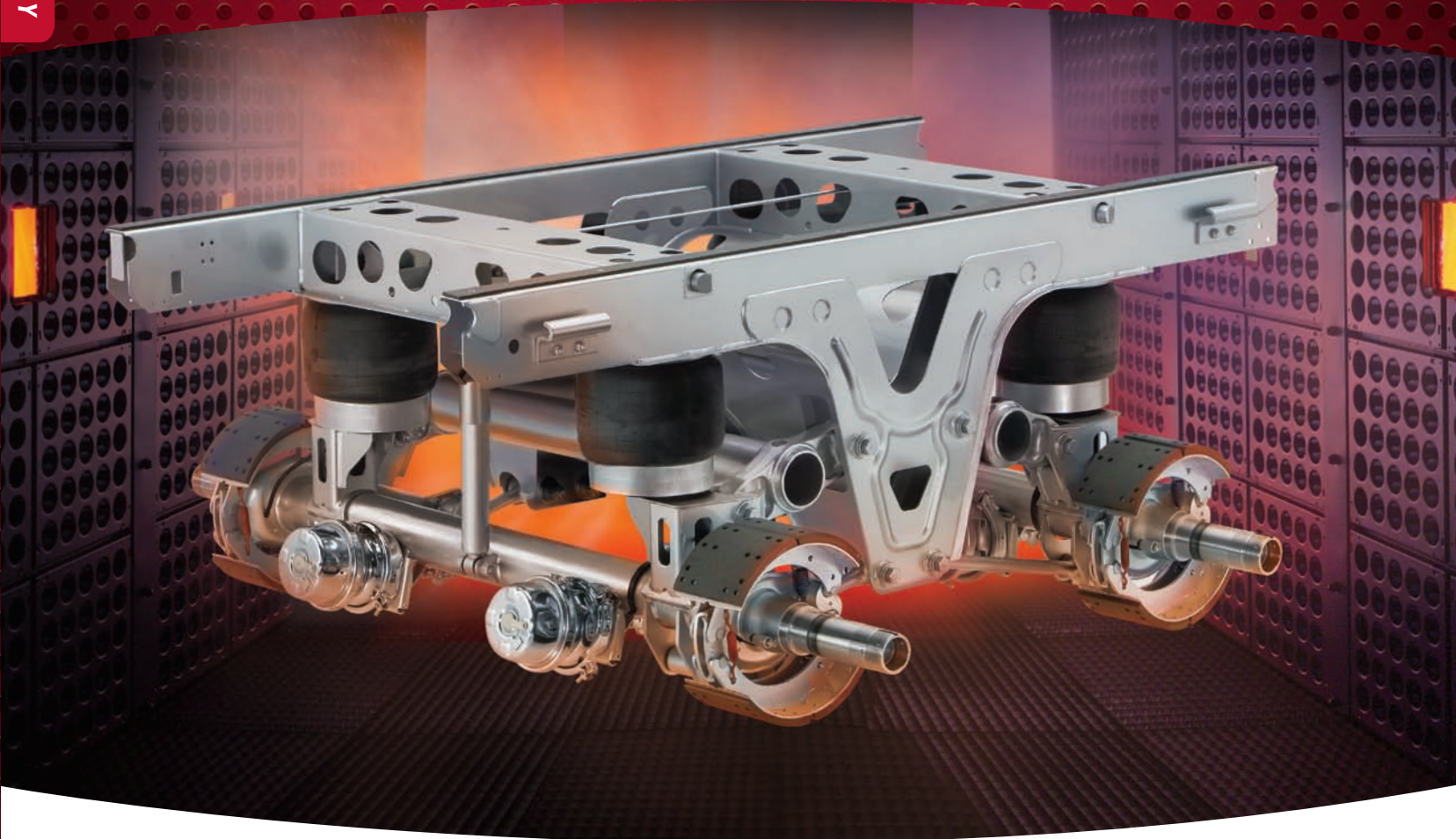

Performance Advantages:

- Reliable performance increases uptime and reduces maintenance expenses
- New PinLoc System helps ensure slider locking pin engagement
- Premium bushing design with industry-leading warranty coverage
- Outstanding ride, stability and dock walk prevention by design

MPG  SERIES™

MERITOR®
An **ArvinMeritor**™ Brand

RIDSENTRY™ MPA SERIES

38,000- and 40,000-Pound Capacities

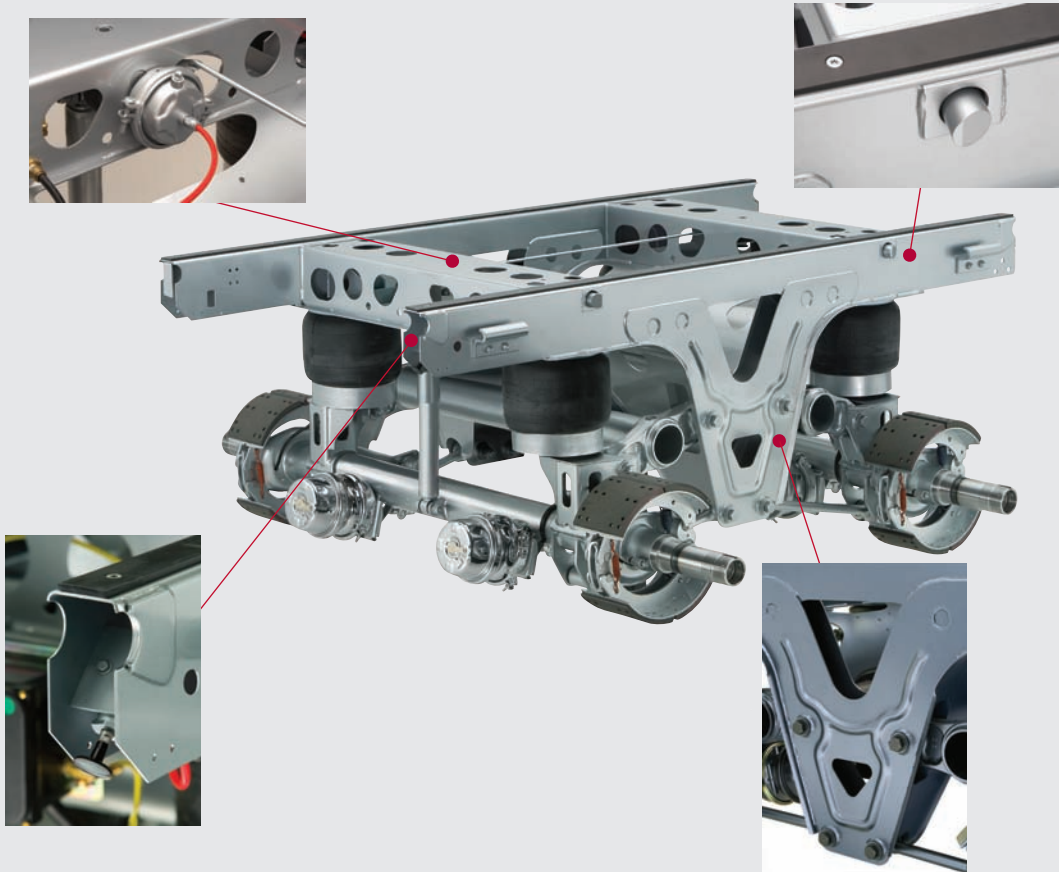

Features and Benefits:

- Optimized to provide reliable performance for dry and refrigerated van trailers
- Best-in-class structural durability
 - High-strength steel frame
 - Outstanding buckling, racking and curbing resistance
- Patent-pending PinLoc™ slider locking system
- Premium bonded rubber bushings with steel thrust washers
 - Industry-leading bushing warranty (7-Years parts/ 5-Years labor)
- E-coating enhances corrosion-resistance
- Lightweight system design
- Premium parallelogram benefits:
 - No dock walk by design
 - Exceptionally smooth ride
 - Eliminates backslap, increasing driver comfort
- Outstanding ride quality
 - Air spring directly over the axle provides 100% air ride
 - Unmatched roll stability
- Industry-leading axles and brakes
 - Available with a wide range of spindle profiles, long-life wheel ends and brakes
 - Premium “MA” Series brake linings extend brake service maintenance intervals. Offers lining choices to meet all application needs

PinLoc™ Slider Locking System. Makes Sliders More Secure Than Ever.

The PinLoc Advantage.

The trucking industry has long needed a solution to problems created when sliders are not securely locked into position before trailers are operated. The resulting damage to trailers and their sliding suspensions has become an industry issue and could be, in certain instances, a safety concern for others on the road.

In all probability, a trailer will travel on public roads at least once per year with its slider pins disengaged. This could lead to potentially serious issues for the driver and the motoring public. It could also lead to economic hardship for the fleet or owner-operator.

The revolutionary PinLoc Slider Locking System provides a one-of-a-kind solution. The system combines industry-exclusive angled locking pins, a parking brake interlock and an air assist. The combination of these features helps ensure slider locking pin engagement.

Testing has shown that at speeds above four miles per hour, conventional pins may not engage. PinLoc helps ensure against this risk and potential damage disengaged pins may cause.



RideSentry with PinLoc is the industry's first trailer suspension system that combines these important security features to:

- Deliver exceptional protection against slider and trailer damage
- Significantly reduce the risk of potential operator error due to disengaged pins
- Reduce the risk of loading yard workers leaving slider pins disengaged
- Provide the security of industry-exclusive angled pins which helps ensure pin engagement even when they don't align with body rail holes
- Push-button air operation makes slider repositioning easy on drivers
- Provide automatic reset that releases pins when the parking brake is released
- Improve driver productivity and operational efficiency



Type 12
Air Chamber

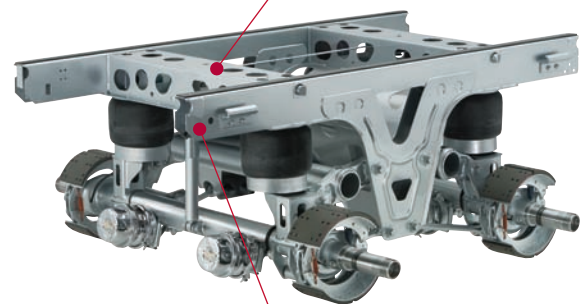

Push-Pull
Valve

For more information, call our ArvinMeritor customer service team at 800-535-5560 or visit www.arvinmeritor.com



ArvinMeritor[™]

Meritor Heavy Vehicle Systems, LLC
2135 West Maple Road
Troy, Michigan 48084 USA
800-535-5560
www.arvinmeritor.com

Litho in USA
Revised 2-10
SP-0667
(13028/11900)
©2007 ArvinMeritor, Inc.